

**FILE**

FINAL

MERCURY CONTROL TECHNOLOGY ASSESSMENT STUDY

Olin Chemicals Group  
Charleston, Tennessee

Preliminary Survey Report  
for the Site Visit of

July 21, 1981

Contract No. 210-81-7107

March 10, 1982

Submitted to:

Alfred A. Amendola, Project Officer  
National Institute for Occupational  
Safety and Health  
Division of Physical Sciences  
4676 Columbia Parkway  
Cincinnati, Ohio 45226

Submitted by:

Donato R. Telesca, Manager,  
Engineering Department  
Enviro Control Division  
11140 Rockville Pike  
Rockville, Maryland 20852

## FOREWORD

A Control Technology Assessment (CTA) Team consisting of members of the National Institute for Occupational Safety and Health (NIOSH) and Enviro Control, Inc. (ECI) met with representatives of the Olin Chemicals Group in Charleston, Tennessee on July 21, 1981 to conduct a preliminary survey on the techniques used to control worker exposure to mercury. Participants in the survey were:

### Enviro Control, Inc.

David D'Orlando, Environmental Engineer  
Robert Reisdorf, Industrial Hygienist

### National Institute for Occupational Safety and Health (NIOSH)

Alfred Amendola, Project Officer

### Olin Chemicals Group

Verrill Norwood, Director of Environmental Affairs  
H. P. Whittle, M.D., Plant Physician  
David Vaughn, Manager of Regional Environmental Affairs  
Lawrence Murray, Chlor-Alkali and Reductone<sup>R</sup> Superintendent  
Leonard Krause, Director of Environmental Hygiene and Toxicology  
Lawrence McFarland, Industrial Hygienist

The preliminary CTA was completed in one day. The study included a review of the chlor-alkali production process, a plant tour, and a discussion on mercury control strategy at the facility.

# TABLE OF CONTENTS

	<u>PAGE</u>
FOREWORD . . . . .	ii
INTRODUCTION . . . . .	1
Contract Background . . . . .	1
Justification for Preliminary Survey . . . . .	1
Summary of Information . . . . .	1
PLANT DESCRIPTION . . . . .	2
PROCESS DESCRIPTION . . . . .	4
Brine System . . . . .	4
Mercury Cells . . . . .	4
MERCURY CONTROL STRATEGY . . . . .	8
Engineering Controls . . . . .	8
Mercury Filling Containers . . . . .	8
Seals . . . . .	8
Process Features Which Control Mercury . . . . .	10
Mercury Removal in Product Purification . . . . .	10
Mercury Drain Troughs and Collection Buckets . . . . .	11
Floor Grating . . . . .	11
Floor Sealant . . . . .	11
Maintenance Program . . . . .	11
Personal Protective Equipment . . . . .	13
Work Practices . . . . .	13
Monitoring Programs . . . . .	16
Biological Monitoring . . . . .	16
Air Contaminant Monitoring . . . . .	17
Medical Program . . . . .	17
CONCLUSIONS AND RECOMMENDATIONS . . . . .	18

## INTRODUCTION

### CONTRACT BACKGROUND

The Mercury Control Technology Assessment Study has been initiated to assess the current technology used to protect the worker from exposure to hazardous levels of mercury. The objective is to identify and evaluate the exemplary methods employed by industries in controlling worker exposure to elemental mercury and mercury compounds. A result of the study will be the publication of a comprehensive document describing the most effective means of controlling emissions and exposures. This report will be available to companies which handle mercury in order to transfer technology within the major mercury using industries. The study will also identify directions where additional research is necessary.

### JUSTIFICATION FOR PRELIMINARY SURVEY

Preliminary surveys are intended to generate information about the control strategies used at various facilities and they will be used to determine where in-depth surveys will be conducted. The Olin Chemicals Group Charleston Chlor-Alkali Plant was selected for a preliminary survey because of the controls in effect to protect the worker from exposure to mercury and mercury vapor. The concern for worker protection at this plant has resulted in a continual effort to maintain control of mercury vapor through effective work practices and process equipment modifications.

### SUMMARY OF INFORMATION OBTAINED

An opening meeting was held during which the objectives of the program were discussed with plant representatives. Information on the chlor-alkali manufacturing process was obtained and a detailed process tour was given to the members of the survey team. The plant's engineering controls were reviewed and discussions were held on air and health monitoring, work practices and use of personal protective equipment at the plant.

## PLANT DESCRIPTION

The Olin Chemicals Group plant in Charleston, Tennessee produces calcium hypochlorite, caustic, chlorine, sodium hypochlorite, and Reductone<sup>R</sup> (a proprietary compound).

The chlor-alkali facility has been in operation since 1962. Additions to the facility were made in 1968 and in 1974. Major renovations affecting mercury control include the installation of a computerized system for anode adjustment in 1973, a hydrogen cooler system in 1974, and a Purasiv unit in 1974. The facility includes two cell rooms, a brine system, caustic and chlorine product separation and purification facilities, mercury retorts, and a waste water treatment system. The cell rooms are two story buildings constructed of steel beams and corrugated steel with grated and cement floors. The cells are located on the second floor (cell level) (Figure 1). The bottom floor is called the cell basement. There are two cell rooms; referred to as the 812 and the 510. Cells in the 812 cell room have 12 sets of 8 anodes each, and cells in the 510 cell room have 10 sets of 5 anodes each.

A total of 800 people are employed at the plant. Seventy-five to one hundred people work in areas where mercury is used.

## PROCESS DESCRIPTION

(Figure 2)

### BRINE SYSTEM

A concentrated brine solution is needed to produce chlorine and caustic in mercury cells. Olin uses Louisiana rock salt to produce brine solution. The salt is kept in a storage bin where it is fed to two saturation tanks to be mixed with water. The brine solution flows to a settling tank where sand and undissolved salt settle out. The solution is filtered to remove impurities and flows into a filtered brine receiver. It is then pumped to the head of the electrolytic mercury cells.

### MERCURY CELLS

The electrolytic mercury cell is a steel channel sloped down at an angle of approximately 7 degrees. It is covered with a sheet of steel which has a layer of rubber under it. The cover is held in place with a series of C-clamps. Under the cover are several sets of anodes (depending on the cell size). The anodes consist of titanium bars coated with rare metal oxides. These bars are positioned under the cover by adjustable lead-in posts which penetrate the cover. Rubber seals are used to prevent leakage around the lead-in posts. The depth of the anode in the mercury cell is controlled by adjusting the lead-in posts. Anode depth must constantly be adjusted in order to optimize the electrolytic reaction taking place in the cell. A computer system is used to actuate a network of chain-linked rotors which adjust the anodes by screwing or unscrewing the lead-in posts through the cover. At the lower end (outlet) of the mercury cell there is an outlet box for removal of the brine solution, a decomposer (a cylindrical reaction vessel approximately 4 1/2 feet high and 3 feet in diameter) for the removal of hydrogen and caustic soda, and a mercury pump for returning the mercury to the higher end (inlet) of the mercury cell.

Mercury, which acts as a cathode, flows along the cell bottom at a specified depth below the anode. The brine solution is introduced to the inlet end of

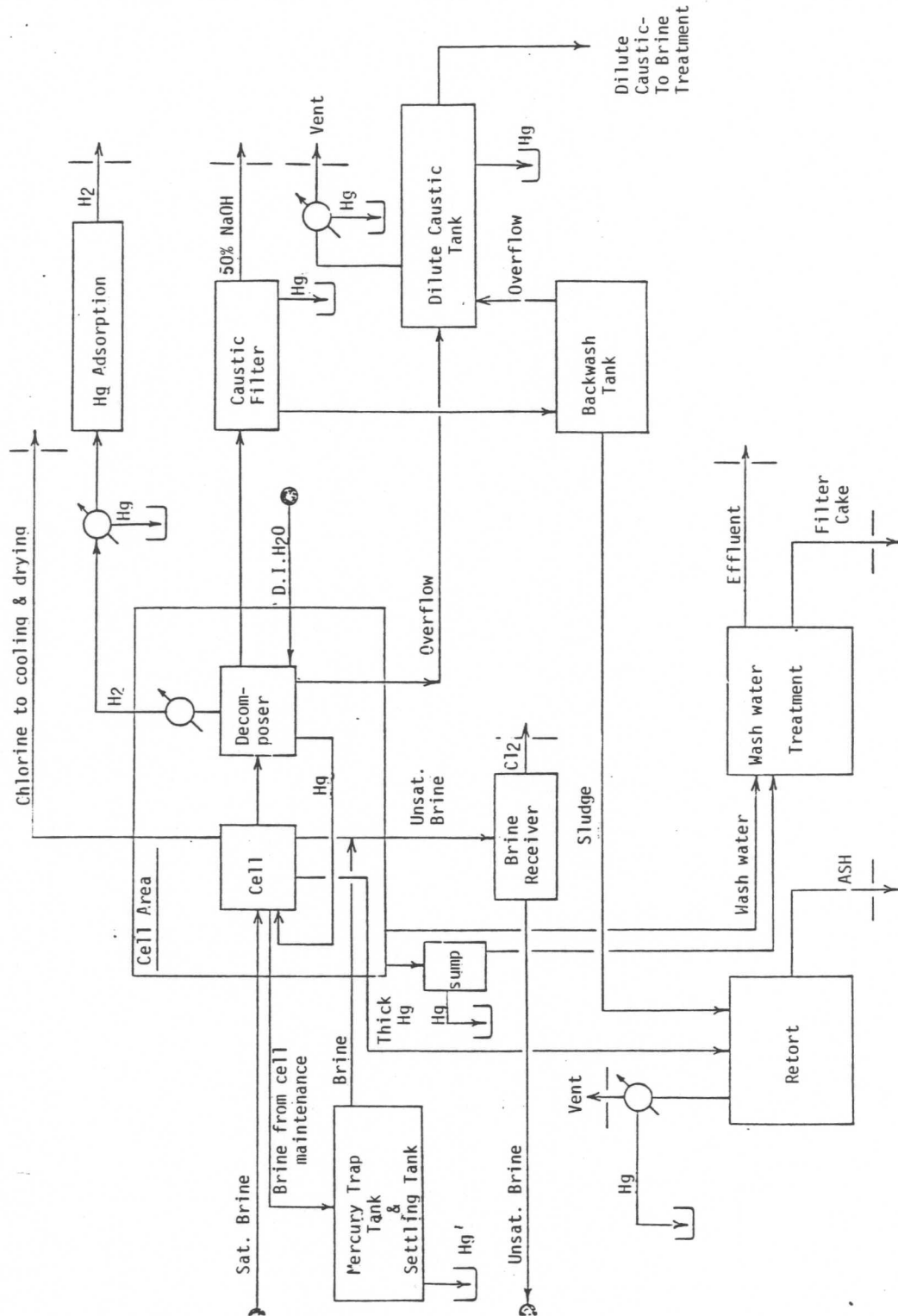

Figure 2. Mercury Recovery in a Typical Chlor-Alkali Process  
Reference: Olin Corporation

the cell and flows between the anode and the mercury cathode. A voltage is applied between the anode and the mercury using large electrical bus lines. The current causes an electrolytic reaction in which the chlorine ions in the solution lose an electron and the sodium ions gain an electron. Chlorine gas bubbles out of solution and flows out of the cell through a collection header located at the inlet of the cell. The sodium combines with the mercury to form an amalgam which flows down towards the outlet box at the outlet of the cell. The heavy sodium amalgam flows below the weak brine. A submerged weir in the outlet box is situated such that only the amalgam can flow past it. Weak brine is decanted off the top through a drain pipe and is returned to the brine system. The amalgam passes through the outlet box into the decomposer where it reacts with water to form caustic soda and hydrogen gas. This is an exothermic electrochemical reaction which is driven by the potential that exists between the amalgam and a graphite packing on the inside of the decomposer. The concentration of the caustic soda produced is controlled at approximately 50% by regulating the flow of water into the decomposer using a rotameter. A level of caustic is maintained in the vessel.

The caustic produced is drained off the top and gravity fed to a filtering and cooling system where it is prepared for distribution. Hydrogen is also removed from the top of the vessel. It is cooled in order to condense and remove mercury vapor passed through the Pura-siv<sup>R</sup> unit and is then used as fuel for the plant's boilers. The mercury (stripped of sodium) flows through a pipe at the bottom of the decomposer and into a mercury sump. A centrifugal sump pump is used to return the mercury to the inlet end of the cell.

During normal cell operations, impurities from brine collect on the mercury to form "thick mercury" or mercury "butter." Once every 3-6 months, this material is removed from the cells as follows:

- Contaminated brine is drained into the mercury trap tank, which is a baffled sedimentation device; mercury is drained out of the bottom. The brine then flows to a settling tank, where longer residence times (approx. 24 hrs.) allow for final separation and removal of any mercury. Brine is recycled to the process.



- Thick mercury in the cell is moved to the cell outlet with a squeegee, then transferred to buckets using dippers and putty knives. The buckets are covered with water and taken to the plant's mercury reclamation facility.

The reclamation facility consists of two retorts. The "thick mercury" is spread onto rectangular pans and put into the oven of a retort for 6 hours of heating at 750 F. Mercury vapor produced is condensed and returned to the cell rooms for use in the process.

Mercury-containing water at Olin is treated with sodium sulfide. A mercuric sulfide sludge is produced and is removed from the water using a filter press. The sludge is sent to a hazardous waste landfill.

## MERCURY CONTROL STRATEGY

### ENGINEERING CONTROLS

#### Mercury Filling Containers

Every few weeks, additional mercury must be added to the cells to make up for mercury carried through with product and mercury vapor escaping into the air. Mercury is added to the cells from closed, portable mercury pots (Figure 3). The pot is wheeled next to the cell and mercury is allowed to flow from the bottom of the pot through a rubber hose into the cell. The flow is controlled by a hand operated valve located under the pot. Water is maintained over the mercury in the pot to reduce mercury vapor emission. When the unit is not being used, the hose is placed inside the top of the pot so that mercury will not leak onto the floor.

#### Seals

Sealing materials are used throughout the mercury cells in order to prevent the escape of chlorine gas and mercury vapor. Gaskets are used to make an effective seal at the seams where the cell covers are clamped to the sides of the cell channels. Diaphragm seals are used at the points where the lead-in posts of the anodes penetrate the cell cover. EPDM (ethylene-propylene-diene monomer), low oil, 50 durometer, is used in this service. It is resistant to alkalies, oxidizers, and high temperatures.

Special sealing materials are also used on the decomposer and the mercury sump. The seam between the flanged top of the decomposer vessel and the steel cover bolted to it requires a sealing material which will not fail when subjected to the heat of reaction in the vessel. Asbestos gaskets are used in straight mercury service. Where chlorine is also present, Neoprene or Hypalon<sup>R</sup> must be used. Sealing material is used to seal the connection between the mercury sump and the mercury pump base-plate (Figure 4) so that vapor from the hot liquid mercury will not escape into the ambient air. All flanges and valves in the mercury system are similarly sealed.

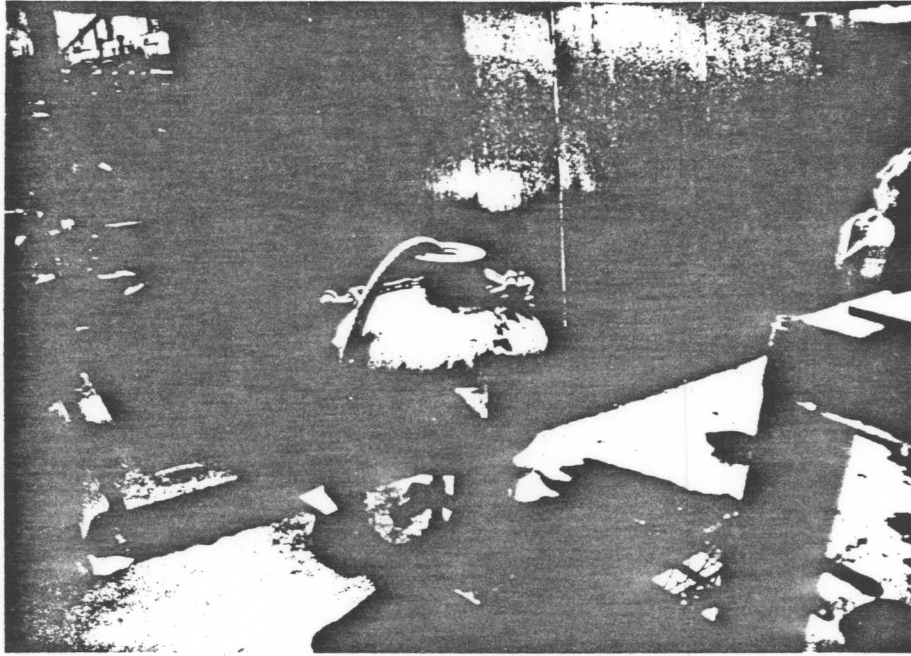

Figure 3. Mercury Addition Pot

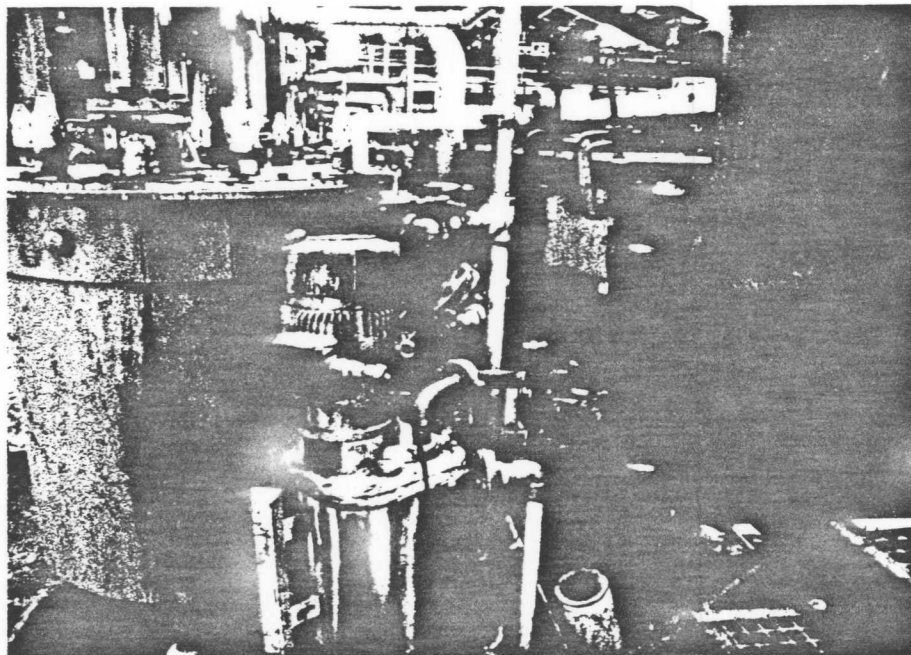

Figure 4. Mercury Sump Pump

## Process Features Which Control Mercury

Several features of the chlor-alkali manufacturing process also help to control mercury vapor emission. Liquid levels which are maintained over the mercury in the electrolytic cells, outlet boxes, and decomposers help to reduce the amount of mercury vapor escaping into the ambient air. These liquids are the brine solution in the cell and the outlet box and the caustic soda in the decomposer. Additionally, fresh water is continuously added to the decomposer inlets and mercury return sumps to maintain a level of water above the mercury in them.

Elemental mercury in liquid streams settles out whenever the liquid is stored or its velocity decreases. Numerous drain connections are located on tanks and pipelines to allow for removal, collection (under aqueous layer to minimize worker exposure), and recycle of the mercury.

Vacuums which exist in parts of the process help to prevent mercury vapor from escaping. The decomposer inlets, the mercury return sumps, and the retorts are operated under a slight vacuum. Retorts are also allowed to cool for 12 hours before opening the doors. This minimizes vapor which may escape when unloading sludge trays.

## Mercury Removal in Product Purification

Byproduct hydrogen gas exits the decomposer with certain levels of water and mercury. The gas is cooled to approximately 5°C by a primary and a secondary heat exchanger, using cooling-tower water and chilled water, respectively. Water and mercury are drained from each cooler into a pipeline separator from which mercury drains into a seal tank for recovery. The cold hydrogen then travels through either Pura-siv<sup>R</sup> or carbon beds for final mercury removal. The beds are heat-regenerated every 24 hours, with regeneration gas passing through a cooler, followed by a separator. Mercury is drained from the separator and recovered. Hydrogen is burned in the boiler, sold, or vented to atmosphere.

Fifty percent caustic produced in the decomposer is filtered by precoated filters. When the filters are cleaned, the backwash is collected in a tank. After settling, the mercury-bearing sludge is drained out of the tank into 55-gallon drums and taken to the retort for recovery.

The chlorine gas produced contains little mercury because the mercury condenses before the chlorine leaves the cell.

#### Mercury Drain Troughs and Collection Buckets

The second floor of the cell rooms have floor drainage troughs for collecting mercury-contaminated water generated during cell cleaning or general wash-downs. Vertical drain pipes lead from the troughs to collection buckets on the first floor (Figure 5). The mercury settles to the bottom of the bucket and is removed periodically through another drain pipe. Water is maintained over the mercury in the bucket, and water which overflows the bucket is collected in the first floor grated drains.

#### Floor Grating

Olin has replaced the wooden steps and walkways on the second floors of the cell rooms with grating. FRP (fiberglass-reinforced polyester) is used in this service, mainly due to its ability to withstand attack by wet  $\text{Cl}_2$ . There is no longer a concern with mercury seeping into the cracks in the wood. The grating also greatly increases air flow between the two floors thereby improving the ventilation around the mercury cells.

#### Floor Sealant

The floors on the first floor of the cell rooms are coated with Ceilcote 682 or 505 to minimize absorption of mercury into the cement.

#### Maintenance Program

Olin has a maintenance program around the mercury cells which is designed to detect process leaks at their onset and repair them immediately. A leak

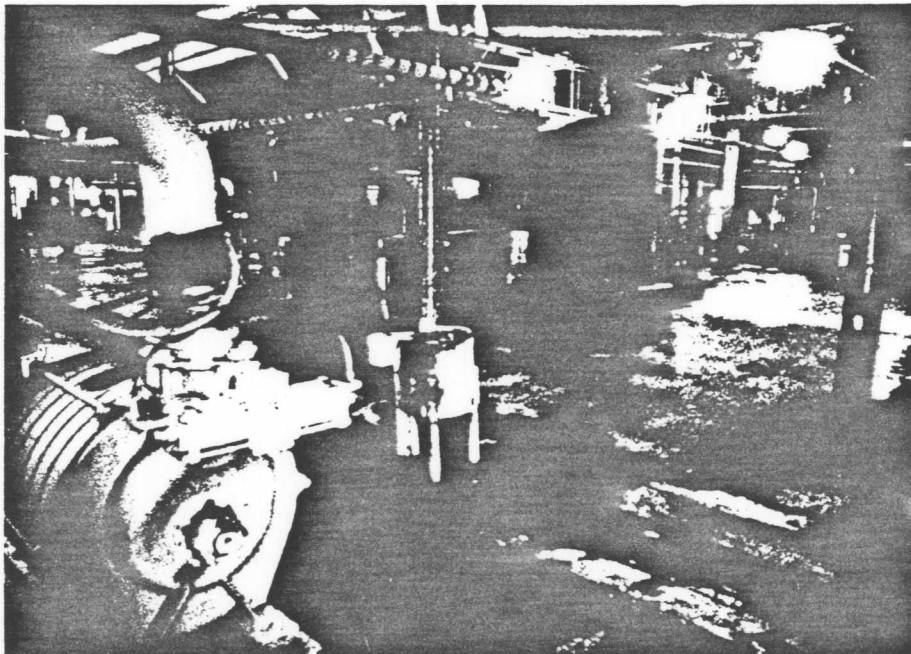

Figure 5. Mercury Collection Bucket and Centrifugal Vacuum for Mercury Spill Clean-up.

inventory is made as part of the routine maintenance rounds. All pipe and fitting connections are inspected and small leaks are repaired before they turn into major problems.

#### PERSONAL PROTECTIVE EQUIPMENT

Personal protective equipment in use at the facility to control or reduce exposure to mercury consists of the following:

- Respirators (3M Disposable Mercury Vapor Respirator # 8707) are worn by all workers whenever sampling indicates that workplace concentrations of mercury vapor exceed  $0.10 \text{ mg/M}^3$ , or whenever the potential for exposure is great (e.g. when working with open mercury). Respirators are worn for a maximum of 1 day. The company's respiratory protection program states that workers are not permitted to wear beards when working in a controlled area for more than 4 hours in any day or 20 hours in any week.
- Cell maintenance workers wear company supplied uniforms which are changed and laundered daily. The uniforms are made of 65% polyester and 35% cotton, a blend which this company has determined through testing to be resistant to mercury penetration and absorption. Clothing is laundered at the facility using soap and water. Double washes of clothing are conducted.
- Rubber boots are supplied to cell maintenance workers. These are changed weekly and cleaned (with soap and water) at the plant's laundry. Other rubber and plastic materials used by workers, such as hard hat bands and facepieces of chlorine gas escape respirators, are also cleaned on a weekly basis.
- Gloves (leather or rubber depending on application) are also worn for certain tasks where contact with liquid mercury is likely.

#### WORK PRACTICES

The following list summarizes the work practices (including personal hygiene practices) in effect to control exposure to mercury:

- Smoking, eating or drinking are not permitted in process areas.
- Food is not permitted in process areas.
- Employees must wash their hands before eating.
- Showers are required for all cell maintenance workers. Shower facilities include a "clean side" and a "dirty side." Workers must pass through the shower to the "clean side" in order to change back into street clothes.

- During the hot season, first shift hours are changed from 7:30 a.m. - 4:00 p.m. to 5:00 a.m. - 2:00 p.m. to avoid working during the hottest part of the day. Plant representatives feel that this procedure helps to reduce exposure to mercury vapor.
- Spills are cleaned up immediately using a central vacuum system.
- Floors are cleaned daily using hose and water.
- Spare equipment is utilized to minimize the amount of time mercury is exposed and to allow contaminated equipment to cool prior to performing maintenance.

This facility practices the following requirements necessary for Chlor-Alkali cell rooms to qualify for section 61.53(c) (4) of the National Emission Standards for Hazardous Air Pollutants.

1. Source testing of the mercury cell chlor-alkali cell room will not be required if the following cell procedures are in effect:
  - a. Chlorine cells and end box covers will be installed, operated and maintained in a manner to minimize leakage of mercury and mercury-contaminated materials.
  - b. Daily inspection shall be made by operating personnel to detect leaks, and immediate steps to stop the leaks will be taken.
  - c. High housekeeping standards shall be enforced and any spills of mercury shall be promptly cleaned up mechanically, chemically and/or by other appropriate means. Each cell room facility shall have available and shall employ a well-defined procedure for handling these situations.
  - d. Floor seams shall be smoothed over to minimize depressions and to facilitate washing down of the floors.
  - e. All floors will be maintained in good condition, free of cracking and spalling, and shall be regularly inspected, cleaned, and to the extent practical, chemically decontaminated.
  - f. Gaskets on denuders and hydrogen piping shall be maintained in good condition. Daily inspection shall be made to detect hydrogen leaks and prompt corrective action taken. Covers on decomposers, end boxes, and mercury pump tanks shall be well maintained and kept closed at all times except when operation requires opening.
  - g. Precautions shall be taken to avoid all mercury spills when changing graphite packing in vertical decomposers. Mercury-contaminated graphite shall be stored in closed containers or under water or chemically treated solutions until it is processed for reuse or disposal.



- h. Where submerged pumps are used for recycling mercury from the decomposer to the inlet of the chlorine cell, the mercury shall be covered with an aqueous layer maintained at a temperature below its boiling point.
- i. Each submerged pump shall have a vapor outlet with a connection to the end box ventilation system. The connection shall be under a slight negative pressure so that any vapors flow into the ventilation system.
- j. Unless vapor tight covers are provided, end boxes of both inlet and outlet ends of chlorine cells shall be maintained under an aqueous layer which is sufficient to prevent boiling.
- k. End boxes of cells should be either maintained under a negative pressure by a ventilation system or should be equipped with fixed covers which are leak tight. The ventilation system or end box covers should be maintained in good condition.
- l. Any drips from hydrogen seal pots and compressor seals shall be collected and confined for processing to remove mercury, and these drips shall not be allowed to run on the floor or in open trenches.
- m. Solids and liquids collected from back-flushing the filter used for alkali-metal hydroxide shall be collected in an enclosed system.
- n. Impure amalgam removed from cells and mercury recovered from process systems shall be stored in an enclosed system.
- o. Brine shall not be purged to the cell room floor. Headers or trenches shall be provided when it is necessary to purge brine from the process. Purged brine will be returned to the system or sent to a treating system to remove its mercury content.
- p. A portable tank shall be used to collect any mercury spills during maintenance procedures.
- q. Good maintenance practice shall be followed when cleaning chlorine cells. All cells when cleaned shall have any mercury surface covered continuously with an aqueous medium. When the cells are disassembled for overhaul maintenance, the bed plate shall be either decontaminated chemically or thoroughly flushed with water.
- r. Brine, alkali-metal hydroxide, and water wash process lines and pumps shall be maintained in good condition and leaks shall be minimized. Leaks shall be corrected promptly, and in the interim, the leaks will be collected in suitable containers rather than allowed to spill on floor areas.

If this option is chosen, the emissions allocated as the cell room emissions will be assumed to be 1300 grams per day per plant.

2. The maximum emissions allowable from the process streams (hydrogen stream and end box ventilation stream) of a plant choosing this option would be 1000 grams per day per plant.
3. Emission testing of cell room effluents is not required if a facility complies with Section 61.53(c) (4), however, emission testing of the process gas streams will be required unless a waiver of emission testing of the process gas streams is obtained.

## MONITORING PROGRAMS

### Biological Monitoring

All cell maintenance workers take part in the biological monitoring program which began in 1964. This involves monthly monitoring of workers' urine to determine the concentration of mercury. Spot samples, as opposed to 24-hour samples, are collected. Urine-albumin concentrations are also checked as a measure of kidney function.

If a worker's urine-mercury concentration reaches 0.26 to 0.36 milligrams per liter (mg/L), a second sample is taken within one week. In addition that employee's work habits and recent medical history are reviewed. If the urine-mercury concentration exceeds 0.36 mg/L another sample is taken immediately to check on the accuracy of analysis. If the concentration remains above 0.36 mg/L, the worker is relocated to an area where the potential for exposure to mercury is lower. In addition, if any 2 samples in a 3 week period exceed 0.36 mg/L, a worker will be relocated. A worker will be reinstated when two consecutive urinalyses indicate 0.25 mg/L of mercury or less.

Plant representatives including the plant physician have observed seasonal variation in workers' urine-mercury concentrations. Concentrations are generally higher in the summer months and lower in the winter months. Plant representatives believe that this variation is a function of ambient temperature and its direct effect on the vaporization of mercury.

## Air Contaminant Monitoring

Periodic monitoring is conducted to determine the concentration of mercury vapor associated with various jobs and locations. This involves weekly area monitoring to determine the time-weighted-average (TWA) concentration of mercury vapor. Monitoring is conducted in the cell room, control room, lunch room, break room and elsewhere as needed. Personal monitoring to determine the employee TWA concentration of mercury vapor is conducted twice a year.

Monitoring for mercury vapor involves the use of personal sampling pumps with Hopcalite as the adsorption medium.

Personal monitoring has identified certain activities which have a high potential for exposure to mercury vapor. These are:

- repacking the decomposer
- mercury pump maintenance
- cleaning the bottom of the cells

Respirators are worn during these activities.

## Medical Program

Physical examinations are given to all workers. In the case of cell maintenance workers, emphasis is placed on early detection of kidney disorders as well as on signs or symptoms of mercurialism.